

# WBP-200

SINGLE CHANNEL WIRELESS BELTPACK  
WB-200 SERIES WIRELESS INTERCOM  
SYSTEM

## OWNERS MANUAL



**ALTAIR ELECTRONICS DESIGN**

~~EQUIPOS EUROPEOS ELECTRÓNICOS S.A.I.~~



Avda. de la Industria s/n. 28760 TRES CANTOS-MADRID  
(AIN).



34-91-761 65 80

34-91-804 43 58

[altair@altairaudio.com](mailto:altair@altairaudio.com)

[www.altairaudio.com](http://www.altairaudio.com)



- 1. INTRODUCTION ..... 3**
- 2. SWITCHES, CONTROLS, ADJUSTMENTS AND CONNECTORS ..... 3**
  - FRONT PANEL ..... 4
  - REAR PANEL ..... 4
- 3. OPERATION..... 4**
  - HEADSET CONNECTION ..... 5
  - CALL SWITCH ..... 5
  - MIC ON/OFF/PUSH TO TALK SWITCH (TALK) ..... 6
  - BUZZER ON/OFF SWITCH ..... 6
  - VOLUME UP/DOWN SWITCH ..... 6
  - ON/OFF SWITCH ..... 6
  - IN RANGE LED ..... 7
  - VIBRATOR ON/OFF ..... 7
  - STANDBY MODE..... 7
  - MIC GAIN ADJUSTMENT ..... 7
  - SIDETONE GAIN ADJUSTMENT ..... 7
  - BELTPACK REGISTRATION ..... 8
  - BELTPACK DEREGISTRATION ..... 8
  - DC-IN CONNECTOR..... 8
- 4. SPECIAL OPERATIONS..... 9**
  - ACTIVATING THE MICROPHONE PHANTOM POWER ..... 9
  - CANCELLING THE BUZZER ..... 9
  - CHANGING THE BATTERIES..... 9
- 5. SPECIAL RECOMMENDATIONS ..... 10**
  - TROUBLESHOOTING GUIDE ..... 11
- 6. BATTERY CHARGER ALTAIR WBPC-200..... 11**
  - CHANGING THE VOLTAGE AND THE FUSE ..... 12
  - CONNECTING TO THE MAINS..... 13
  - BELTPACK BATTERY CHARGE..... 13
- 7. TECHNICAL SPECIFICATIONS ..... 14**
- 8. WARRANTY ..... 15**



## 1. INTRODUCTION

Congratulations on your purchase of the **ALTAIR** single channel wireless beltpack **WBP-200** of the **WB-200** series wireless intercom system. There are a lot the characteristics that make of the **ALTAIR WB-200** series one of the most highlighted in the audio professional market, some are enumerated here:

- Dual pre-amble diversity antenna system detects and selects the higher radio signal ensuring better coverage and minimum dropouts.
- Digital encryption process allows high security conversations.
- Beltpack uses internal antennas for a more comfortable belt fitting.
- As a battery dependent device, special care has been taken as battery status indication with led bargraph, low consumption “call receive” mode and general low power circuitry.
- Out of range indication, helps the user to understand radio coverage and anticipate to possible communication failures.
- 10 HOURS battery life in full duplex

Before beginning it is important to read this manual. This manual will help you to install and use your new beltpack. It is very important to read it carefully, mainly the paragraphs marked as NOTE, PRECAUTION and DANGER, for your security.

Save the original packing, you can re-use it to transport the unit. **NEVER SHIP THE ALTAIR WBP-200 WITHOUT ITS ORIGINAL PACKING.**







## 2. SWITCHES, CONTROLS, ADJUSTMENTS AND CONNECTORS



These are the switches, controls, adjustments and connectors that you can find in your ALTAIR intercom beltpack. The description and explanation of each one will be found in the corresponding section.



### FRONT PANEL

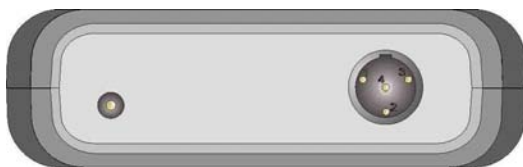

-  CALL - CALL SWITCH.
-  ON/OFF/PTT MIC - MIC SWITCH.
-  BUZZ ON/OFF - BUZZER SWITCH.
-  ON/OFF - ON/OFF SWITCH.
-  VOLUME - VOLUME UP/DOWN
-  IN RANGE - IN RANGE LED.
-  LOW - LOW BAT LED.

### REAR PANEL



-  - HEADSET
-  - DC-IN

CONNECTOR.

### 3. OPERATION

The WB-200 series intercom system are designed to allow maximum easy communications operation between the different control areas in music or theatre live performances, television, cinema, conference halls, and whatever broad events where multiple and fast communications are required, by means of its simultaneous listening-speaking operation system.

The Single Channel Wireless Beltpack WBP-200 unit was designed for intensive use in portable applications. An unbreakable plastic belt clip enables easy and secure suitability. Call signalling is Triple, visual, audible and with a vibration for improving adaptability. The unit can be configured for dynamic or electret microphones enabling the use of different types of headsets and hands-free earpieces in the market.

The WBP-200 is provided with a ON/OFF switch, a CALL switch, a MIC on/off switch, BUZZER on/off switch, headphones volume control, etc...

In order to begin to use its new beltpack ALTAIR WBP-200, first it turn on the base station on which the beltpack is registered (if it is not registered to any base, goes to the registry section).



Once turn on the base station, push the on/off the beltpack leds light on and last a little while it will is turn on) and will vibrate (if the vibrator is turn on), operative.



switch of the beltpack. All sound the buzzer (if buzzer indicating that it is

If the base on which it is registered finds within its reach, the LED of IN will begin to blink and the audio will be opened. At this moment you can begin your beltpack ALTAIR WBP-200.



RANGE to use

If the beltpack ALTAIR WBP-200 remains turned on during a period of ten minutes without connection to the base station (the base station is turned off, outside range, or the beltpack is not registered to any base station), it will be turned off automatically.

### HEADSET CONNECTION

A TINY Q-G type connector allows to connect a headset and a microphone to the beltpack. The headset impedance must be of 200 or higher (up to 2 K ) and the microphone may be dynamic or electret type.

For the electret microphone type is necessary to enable the phantom power of 9 VDC with an internal preset. In order to obtain more information, consult the special operation section.

The next list shows the XLR pins correspondence:



HEADSET	
PIN 1	0 V (MICROPHONE)
PIN 2	SIGNAL (MICROPHONE)
PIN 3	0 V (HEADPHONES)
PIN 4	SIGNAL (HEADPHONES)

**NOTE:** Headphones could be with a double or single muff. In case of using a double muff headphone, the two speakers should be wired in parallel mode.

### CALL SWITCH

When this to the intercom call signal makes the



CALL

switch is pressed, a call signal is sent to the system and channel in which it is connected the base station. The LED associated with the switch to start blinking; if the vibrator is enabled (see vibrator on/off section for more information) will be vibrate; if the buzzer is enabled (see buzzer on/off section for more information) an intermittent sound takes place during about three seconds, the same as in all the units (wireless beltpacks, beltpacks, base stations, desk stations, master stations, etc.), connected to the same intercom channel.

The IN RANGE led of the base station correspondent to the register number of the beltpack will be blink. In the wireless beltpacks will be turn on the associated led with the wireless beltpack that it is calling (LOW BAT – 1, BUZZ ON/OFF – 2, MIC ON/OFF – 3, IN RANGE – 4). If the call is generated by the base station, all associated led will be turn off.

If the CALL switch is pressed continuously, the duration of the call signal will be higher (the time that the switch is pressed, and approximately 3 seconds more).

If a call signal is generated in an external unit (wireless beltpacks, beltpacks, base stations, desk stations, master stations, etc.), the LED associated with the CALL switch will start blinking, if the vibrator is enabled (see vibrator on/off section for more information) will be vibrate, and if the buzzer is enabled (see buzzer on/off section for more information) an intermittent sound will take place during about three seconds.



### MIC ON/OFF/PUSH TO TALK SWITCH (TALK)

The MIC we are able to channel.



switch allows to enable/disable the microphone, so that speak with other units connected to the same intercom channel.

If the microphone is activated, its associated LED will light up, and on the other hand, if it is disabled, its associated LED will turn off.

The MIC switch has two operation modes. When this switch is pressed quickly the microphone changes its state, if it was enabled, upon being pressed it gets disabled and turns off the associated LED, and if it was disabled, upon being pressed gets enabled and turns on the associated LED.

When the MIC switch is pressed and held, the unit will enter in the special function PUSH TO TALK, this means that the microphone will be enabled until the switch is released.

The unit provides a MIC-KILL (turns off the MIC) system, so that when the mic is enabled it is possible to muted it by the MIC-KILL function of the base station ALTAIR WBP-200 or a master station EF-200, connected to the base station. This MIC-KILL system is compatible with other intercom systems of the market.

The state of the MIC (on/off), it is stored in the unit.

### BUZZER ON/OFF SWITCH

This switch enables/disables the buzzer sound when the unit receives a call and when



the user press a key. Whenever this switch is pressed, and the buzzer is enabled, it will be disabled, and the LED indicator will turn off. On the other hand, if the buzzer was disabled, it will be enabled and the LED indicator will lighten up.

The buzzer also sounds when any switch is pressed, emitting a short hoot, when it is enabled.

The unit provides a BUZZER-KILL (turns off the BUZZER) system, so that when the buzzer is enabled it is possible to muted it by the BUZZER-KILL function of the base station ALTAIR WBP-200 or a master station ALTAIR EF-200, connected to the base station. This BUZZER-KILL system is compatible with other intercom systems of the market.

The BUZZER could be disabled with an internal preset. In order to obtain more information, consult the special operation section.

The state of the BUZZER (on/off), it is stored in the unit.

### VOLUME UP/DOWN SWITCH

The volume switches sent to the headphones. allows attenuating or amplifying the signal This switches adjusts the listen level to the headphones as you wish.

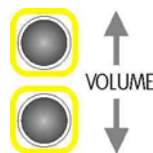

### SWITCH

allows attenuating or amplifying the signal This switches adjusts the listen level to the headphones as you wish.

When volume UP/DOWN switches are pressed, the four leds of the beltpack turn to indicate the volume. There are 10 steps of volume, the LOW BATTERY led indicates the first step, the BUZZ ON/OFF led indicates the fourth step, the MIC ON/OFF led indicates the seventh step and the IN RANGE led the tenth step of volume.

The VOLUME, it is stored in the unit.

### ON/OFF SWITCH

When the beltpack is power off, and the beltpack's all the beltpack leds light on and last a little while it will is turn on) and will vibrate (if the vibrator is turn on), operative.



on/off switch it is pressed, sound the buzzer (if buzzer indicating that it is



If the base on which it is registered finds within its reach, the LED of IN RANGE will begin to blink and the audio will be opened. At this moment you can begin to use your beltpack ALTAIR WBP-200.



RANGE to use

To turn off the beltpack, press and hold two seconds the ON/OFF switch when the beltpack is turned on. In this moment will sound the buzzer (if the buzzer is turn on) and when the ON/OFF switch it is depressed, the beltpack it is turned off.

If the ON/OFF switch it is short pressed, the beltpack will show us the battery status (LOW BAT led – 10%, BUZZ ON/OFF led – 40%, MIC ON/OFF led – 70% and IN RANGE led – 100%).

### IN RANGE LED

The IN station base beltpack is not in



RANGE led when blinks indicates that the beltpack is in the range, if it is turn on without blinking, indicates that the the station base range.

### VIBRATOR ON/OFF

When we press at the same time the MIC ON/OFF and the BUZZ ON/OFF switch we turn on/off the vibrator. If the vibrator it is in on mode, the vibrator turn to off mode and if the vibrator it is in off mode, the vibrator turn to on mode.



If the vibrator it is turned on, when a call is received, the unit vibrates. The state of the VIBRATOR (on/off), it is stored in the unit.

### STANDBY MODE

When the beltpack is turn on and we press the and the the beltpack the beltpack can mode is useful



VOLUME

VOLUME DOWN switch at change to STANDBY mode.



ON/OFF switch the same time, In this mode, receive CALLs, but the audio it is disconnected. This to save battery, since the beltpack less consumes 5 times than in full duplex state.

To exit from STANDBY mode, press the ON/OFF switch briefly.

### MIC GAIN ADJUSTMENT

The mic gain adjustment allows attenuating or amplifying the mic signal. When press the MIC ON/OFF DOWN the four leds of There are 15 steps of mic gain, the LOW BATTERY led indicates the first step, the BUZZ ON/OFF led indicates the eleventh step and the IN RANGE led the fifteenth step of the mic gain.



VOLUME



switch and at the same time the UP or VOLUME switch, the mic gain it is adjusted, the beltpack turn to indicate the mic gain.

The MIC GAIN, it is stored in the unit. Press again to switch on if necessary.

### SIDETONE GAIN ADJUSTMENT

The sidetone gain adjustment allows attenuating or amplifying the own mic signal that we listen in our headphones. When press the BUZZER switch and at the same time the UP or DOWN switch, the sidetone gain it is adjusted, the four



VOLUME



ON/OFF VOLUME leds of the



beltpack turn to indicate the sidetone gain. There are 10 steps of volume, the LOW BATTERY led indicates the first step, the BUZZ ON/OFF led indicates the fourth step, the MIC ON/OFF led indicates the seventh step and the IN RANGE led the tenth step of the mic gain.

The SIDETONE GAIN, it is stored in the unit. Press again to switch on the buzzer..

**BELTPACK REGISTRATION**

Each beltpack can be registered in two different base stations, so that if it loses the range of one, changes the operation to the other base station. Each base station can register a maximum of four beltpacks. See the WBS-200 owners manual for details.

With the base station turned on, press and hold the REGISTER base station switch during six seconds. At this moment the base station will sound (if the buzzer it is turned on) and will blink the IN-RANGE (1-2-3-4) leds corresponding where is going away to register the new beltpack. If the base station has registered four cases already, the function will be reset, and new beltpacks will not be able to be registered until the deregistration of some beltpack is made or deregister all the beltpacks registered in the base station (consults the base station WBS-200 manual for the more information).

If we do not do anything during 60 seconds the function will be reset.

If we pressed key REGISTER again the function will be reset.

With the beltpack that we want to register turned off, turn on pressing the ON/OFF switch maintaining pressed the VOLUME switches (to register it in base 1) or maintaining

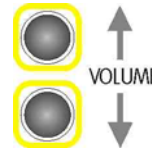

UP/DOWN pressed the



VOLUME (to register it in base 1) or maintaining VOLUME (to register it in base 2).



UP/DOWN and the

BUZZER ON/OFF switches

If everything goes well, the base station will sound (if the buzzer it is turned on) and the beltpack also (if the buzzer it is turned on), the corresponding base station IN RANGE led will turn on and the beltpack IN RANGE led begin to blink.

If the procedure fails, turn off the base station and the beltpack and start again.

Registering process must be near the base station and is not allowed during battery charging.

**BELTPACK DEREGISTRATION**

With the base station turned on, and the deregister turned off, turn on the beltpack pressing pressed the MIC ON/OFF and the switches.



MIC ON/OFF and the



beltpack that is wanted to the ON/OFF switch maintaining BUZZER ON/OFF

The beltpack will start normally, but when it is connected to the base station, this one will be reset and the beltpack will be deregistered.

If the procedure fails, turn off the base station and the beltpack and start again.

**DC-IN CONNECTOR**

The three NiMh, AAA, 900 mA/h batteries of the wireless beltpack must be charged with the ALTAIR WBPC-200 charger by the DC-IN connector. The polarity is tip positive.

Charging time is three hours with the batteries empty. After this 2-3 hours time, the charger sets to trickle (maintenance) mode and can be left alone in the charger. For a full charge, it is recommended a 2 hours minimum charging in this state.

The estimated battery life, in full duplex mode is 10 hours and 50 hours in standby mode, with full charged batteries.





The included NiMh batteries has a shelf discharging time around 2 month. So it is imperative to check the battery status before use: *switch ON the unit and then, press shortly the ON switch*. As a general rule, charge the unit before using the system.

## 4. SPECIAL OPERATIONS

In order to set-up some of the wireless beltpack possibilities, the unit must be opened removing the two external screws of its rear panel.

**NOTE:** *This type of operations takes place with the unit is opened; the best thing should be to carry it out by a qualified technician. Care must be taken to avoid short circuit between battery holders, etc.*

**DANGER:** *Before opening the unit, turn it off. Use of protective glasses when operating batteries.*

**CAUTION:** *Protect the wireless beltpack from the rain and moisture, mostly if it is open. If liquid is spilled into the unit, disconnect it from the mains and consult a qualified service technician.*

### ACTIVATING THE MICROPHONE PHANTOM POWER

The microphone PHANTOM power could be activated or disabled with an internal jumper (JP2/ PHANTOM). With this jumper removed, the phantom power is disabled and with this jumper placed the phantom power is activated.

If an electret microphone is used, the PHANTOM power must be enabled and if a dynamic microphone is used, the PHANTOM power must be disabled. The microphone PHANTOM power is 9 VDC.

It is convenient to place the jumper over one pin for future use.

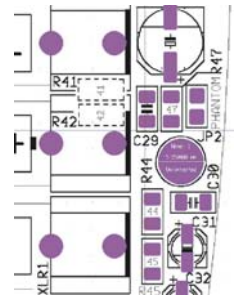

### CANCELLING THE BUZZER

The buzzer can be disabled definitely by removing a jumper JP1/BUZZER located near the buzzer on the upper-right side of the unit.

This jumper defeats the actions of the buzzer key and remote buzzer key. It is convenient to place the jumper over one pin for future use.

Disabling the buzzer guarantees no CALL sounds in any circumstance, as desired in theatre or any other public performance.



### CHANGING THE BATTERIES

The wireless case includes three NiMh (1,2 V) batteries of size AAA and capacity of 900 - 1000 mA/h. In the case it must be replaced one battery, replaces all at the same time, by three equal batteries.

The beltpack can work in case of necessity with three alkaline batteries (1,5 V), size AAA, but it considers that the batteries cannot be charged.

Don't try to use the unit with no batteries or batteries in bad condition; the unit can be damage. When necessary, the unit can be used when charging at the same time. You can either plug the charger when the unit is ON or switch ON the unit when in charging.

**NOTE ON ENVIRONMENTAL PROTECTION:**



After the implementation of the European Directive 2002/96/EU in the national legal system, the following applies:

Electrical and electronic devices may not be disposed of with domestic waste. Consumers are obliged by law to return electrical and electronic devices at the end of their service lives to the public collecting points set up for this purpose or point of sale. Details to this are defined by the national law of the respective country.

This symbol on the product, the instruction manual or the package indicates that a product is subject to this regulations.

By recycling, reusing the materials or other forms of utilising old devices, you protecting our environment.

## 5. SPECIAL RECOMMENDATIONS

Don't place the unit in close proximity to metallic surfaces and/or other electronic equipment in order to avoid interferences.

In case of lose of range, reorient your body position to face up the base unit position.

Take special attention to the placement of the base station when trying to reach all the possible placements of the beltpacks specially when concrete walls or other absorbing materials are in between.

As the batteries used has a shelf discharge mechanism of around 3 month, it is advisable to charge the units just next day of use.

In order to have the units ready to operate, it is a good practice to make a full charge of all the units every two month.

Extract the batteries out of the unit if you plan to store it for a long time.



<b>TROUBLESHOOTING GUIDE</b>	
<b>WHEN:</b>	<b>POSSIBLE CAUSES AND SOLUTIONS</b>
Abnormal low range.	Switch off and then on the base station with the beltacks on.
Beltack switch off immediately after switch on.	-Batteries are low. Check battery status. Charge it. -Battery contacts failure. Open the unit, remove the batteries and force inwards both contacts and clean it. Then insert batteries accordingly.
Beltack refuse to switch-off.	-Wait for 1 to 5 minutes until unit switch-off itself. -In the case auto shut-off is not operating, open the unit and remove and insert again one battery.
Poor charge.	-Disconnect the charger and try it again. Check charge time to be around 2 to 3 hours. -Possible battery contact failure. Refer to previous notes.
Suddenly Beltack switch off.	-Base unit has been switched off -Batteries can be low, check battery status. Charge it if necessary. -Possible battery contact failure. Refer to previous notes.
Charger led always is green when charging.	-Check charger plug contacts. Try with another plug. Try to charge another beltack verifying charger. -Batteries are so low that the unit is not able to start charging. Make a small external battery charge and try again to charge normally.
Unit refuse to charge after a long period of not in use.	Shelf-discharge of the batteries. Wait for 10 minutes onto the charger to verify charging normally.
Bad coverage in some areas.	-Try another better position of the base unit. -Study the possibility of installing a higher gain directional antenna on the base unit.



## 6. BATTERY CHARGER ALTAIR WBPC-200

The battery charger ALTAIR WBPC-200 allows to charge up to four beltpacks ALTAIR WBP-200 simultaneously. The charge time is approximately of three hours with the batteries totally discharged. After this 2-3 hours time, the charger sets to trickle (maintenance) mode and can be left alone in the charger. For a full charge, it is recommended a 2 hours minimum charging in this state.

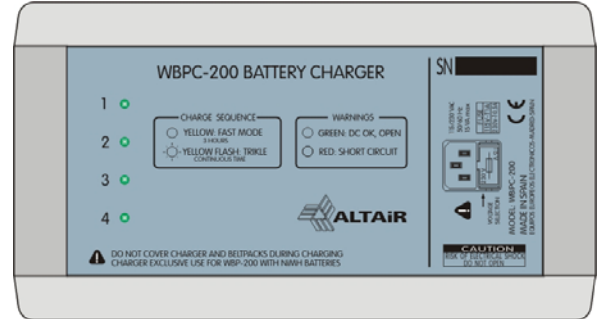

### CHANGING THE VOLTAGE AND THE FUSE

The battery charger ALTAIR WBPC-200 is set to operate at 230V, 50-60Hz and at 115V, 50-60Hz.

- 1 Make sure that the unit is disconnected of the mains.
- 2 In the unit rear panel, is placed the mains connector, the mains selector and the fuse holder. The box bellow this mains connector is called fuse holder + mains selector. Take out the fuse holder + mains selector.
- 3 Upon extracting the fuse holder, the fuse will appear, take out it and change for the new one.
- 4 Insert the fuse holder into the mains connector again, without spin it (make sure that the voltage to which it is going to connect the unit remains indicated in normal position, not inverted), if you only wants to change the fuse. If what you want are change the mains voltage, rotate the fuseholder until remains the mains voltage to which it is going to connect the unit in normal position, not inverted.

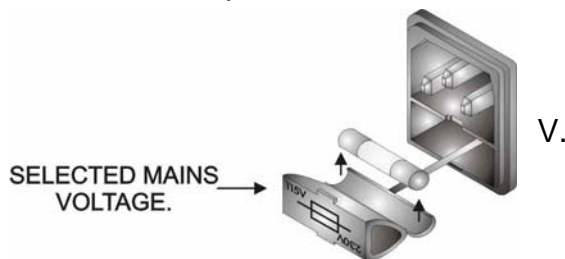

Battery charger ALTAIR WBPC-200 set up to 115 V.

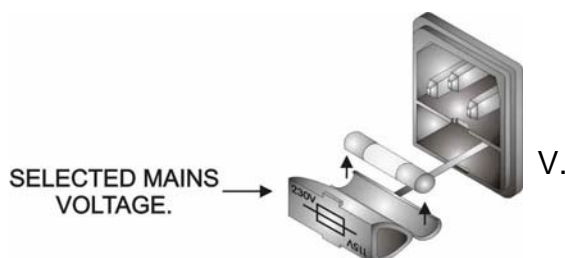

Battery charger ALTAIR WBPC-200 set up to 230 V.



- 5 Make sure that the fuse is the right one for the selected voltage:

FUSE (230V. 50-60 Hz)	FUSE (115V. 50-60 Hz)
T0,5A.	T1A.

**NOTE:** The fuseholder provide a place for spare fuse.

**CAUTION:** Always make sure upon changing the fuse, that this is the adequate for the selected mains voltage (T1A for 115V and T0,5A for 230V).

## CONNECTING TO THE MAINS

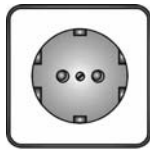

The connection of the battery charger ALTAIR WBPC-200 power supply to the mains takes place by a standard cord included in the box.



- 1 Make sure that the beltpack are disconnected from the battery charger.
- 2 Insert the female I.E.C. connector of the tripolar cable into the unit power supply male connector, placed at the rear panel.
- 3 Insert the male connector of the tripolar cable into the mains plug.
- 4 In that moment the charge LEDs indicators will light in green colour, indicating that the unit is turned on.

**CAUTION:** Make sure that the mains voltage is the correct as well as their fuse is the adequate.

## BELTPACK BATTERY CHARGE

The battery charger ALTAIR WBPC-200 has four connectors to allow the charge up to four wireless beltpacks at the same time.

Take any of the battery charger connector and insert it in a wireless beltpack connector. If the battery charger is connected, the connector associated LED of the battery charger will change from green to orange, indicating that the wireless beltpack batteries are charging.

If the beltpack is turned off, the LEDs battery bargraph will begin to blink from down to up indicating the charger connection. If the beltpack is turned on, will not be changes of these LEDs unless the key ON/OFF is pressed briefly.

After three hours time, the charger sets to trickle (maintenance) mode and can be left alone in the charger, and the LED associated to the charger connector turn intermittent between green and orange. For a full charge, it is recommended a 2 hours minimum charging in this state.

If a problem appears in one of the connectors, and the consumption increases, the battery charger ALTAIR WBPC-200 will protect itself, and the LED associated to this connector will turn to red colour.



## 7. TECHNICAL SPECIFICATIONS

### PREAMPLIFIER

<b>MICROPHONE TYPE:</b>	<ul style="list-style-type: none"><li>• Dynamic or electret.</li></ul>
<b>INPUT IMPEDANCE:</b>	<ul style="list-style-type: none"><li>• 4K7.</li></ul>
<b>NOMINAL LEVEL:</b>	<ul style="list-style-type: none"><li>• -45 dBu.</li></ul>
<b>PHANTOM VOLTAGE:</b>	<ul style="list-style-type: none"><li>• +9 VDC (internal preset).</li></ul>

### HEADSET AMPLIFIER

<b>IMPEDANCE:</b>	<ul style="list-style-type: none"><li>• 200 (nominal), 2K (maximum).</li></ul>
<b>MAXIMUM LEVEL:</b>	<ul style="list-style-type: none"><li>• 14 Vpp (200 ).</li></ul>
<b>OUTPUT POWER:</b>	<ul style="list-style-type: none"><li>• 200 mW (200 ).</li></ul>
<b>FREQUENCY RESPONSE:</b>	<ul style="list-style-type: none"><li>• 250 Hz - 3500 Hz.</li></ul>

### RADIO

<b>FREQUENCY:</b>	<ul style="list-style-type: none"><li>• 1900 MHz band.</li></ul>
<b>MODULATION:</b>	<ul style="list-style-type: none"><li>• GFSK/TDMA</li></ul>
<b>TRANSMIT POWER:</b>	<ul style="list-style-type: none"><li>• +22 dBm typically.</li></ul>
<b>RECEIVE SENSITIVITY:</b>	<ul style="list-style-type: none"><li>• -92 dBm typically.</li></ul>

### BATTERY

<b>TYPE:</b>	<ul style="list-style-type: none"><li>• 3 x NiMh, 1.2 Volts, 900-1.000 mAh</li></ul>
<b>CHARGING TIME:</b>	<ul style="list-style-type: none"><li>• 2-3 hours. Fast charging mode.</li></ul>
<b>CHARGER:</b>	<ul style="list-style-type: none"><li>• External charger WBPC-200.</li></ul>

### SIDETONE CANCELLATION

- Adjustable -12 – 30 dB @ 1 KHz

### BUZZER

- 90 dBA.

### CONTROLS

- Call, Volume level, Mic On/Off/PTT, Buzzer On/Off, Vibrator On/Off.

### INDICATORS

- Call, Battery status, Low Batt, Mic On/Off, Buzz On/Off, In range led.

### CALL SYSTEM

- Light, Vibration and Buzzer.

### DIMENSIONS

- 120x80x25 mm.

### WEIGHT

- 175 gr. Net.

**NOTE:** Technical specifications are subject to variation without previous notice.



### 8. WARRANTY

This unit is warranted by Equipos Europeos Electrónicos to the original user, against flaws in the manufacturing and in the materials, for a period of one year, starting from the date of sale.

Flaws due to wrong use of the unit, internal modifications or accidents, are not covered by this warranty.

There is no other warranty expressed or implicit.

Any faulty unit must be sent to the dealer or the manufacturer. The serial number of the unit must be included for any request to the technical service.

Equipos Europeos Electrónicos reserves the right to modify the prices or the technical specifications without further notice.

#### BELTPACKS:

SERIAL NUMBER .....

SERIAL NUMBER .....

SERIAL NUMBER .....

SERIAL NUMBER .....

#### BELTPACK CHARGER:

SERIAL NUMBER .....



## ELECTRONICS DESIGN

**EQUIPOS EUROPEOS ELECTRÓNICOS, S.A.L**

~~Avda. de la Industria, 30. 28760 TRES TORRES-MADRID (SPAIN).~~

34-91-761 65 80

34-91-804 43 58

[altair@altairaudio.com](mailto:altair@altairaudio.com)

[www.altairaudio.com](http://www.altairaudio.com)

# European Union Waste Electronics Information Unión Europea Información sobre residuos electrónicos

## **Waste from Electrical and Electronic Equipment (WEEE) directive**

The WEEE logo signifies specific recycling programs and procedures for electronic products in countries of the European Union. We encourage the recycling of our products. If you have further questions about recycling, contact your local sales office.

## **Directiva sobre Residuos de Aparatos Eléctricos y Electrónicos (RAEE)**

El logotipo de la Directiva RAEE se refiere a los programas y procedimientos específicos de reciclaje para aparatos electrónicos de países de la Unión Europea. Recomendamos el reciclaje de nuestros productos. Si tiene alguna consulta, póngase en contacto con su Distribuidor.

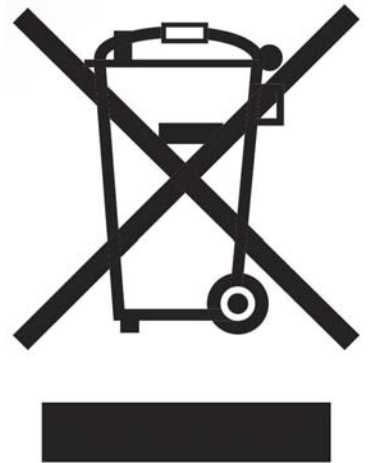

Information based on European Union WEEE Directive 2002/96/EC

Información basada en la Directiva de la unión europea RAEE 2002/96/EC y el Real Decreto 208/2005

**AUDIO ELECTRONICS DESIGN**

**EQUIPOS EUROPEOS ELECTRÓNICOS, S.A.L**

Avda. de la Industria, 50. 28760 TRES CANTOS-MADRID (SPAIN).



34-91-761 65 80



34-91-804 43 58



[altair@altairaudio.com](mailto:altair@altairaudio.com)

[www.altairaudio.com](http://www.altairaudio.com)